

INSTALLATION INSTRUCTIONS

FOR LUGA SHOP
PCB HOLDERS

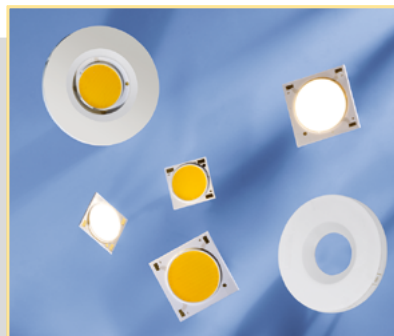

PCB HOLDERS FOR LUGA SHOP MODULES

For simple and secure fixation and electrical connection of LUGA PCBs

With separate holders a simple and secure fixation and electrical connection of LED modules is possible.

Dependent on the used thermal conductive material and the power classes the expected service life times can differ from the values on the data sheet LUGA.

For LUGA Shop Gen. 5/6/7
with shape: 19x19 mm and 28x28 mm



LUGA Shop PCB Holders

- **SAFE AND SIMPLE INSTALLATION**
 - Users can tell immediately whether the module has been correctly inserted
- **IMPROVED DESIGN**
 - No visible fixing holes
- **LARGER CONNECTION AREA FOR CABLES**
 - Easy creation of electrical contacts
- **EXCHANGEABLE LED MODULES**
 - Using the holder makes it possible for trained staff to easily exchange LED modules, provided ESD protection measures are observed
- **TUNEABLE WHITE LUGA MODULES**
 - Existing push-in connection for Tuneable White modules

Two-piece PCB Holders – Type 89730/31

For LUGA modules Shop/C

PCB holders, two-piece, for fixation and electrical connection of LED modules of series LUGA Shop and C.
Consisting of base holder and cover
Material: PBT, white

Dimensions (ØxH): 50x6.5 mm
Fixing holes for screws M3
Hole distance: 35 mm

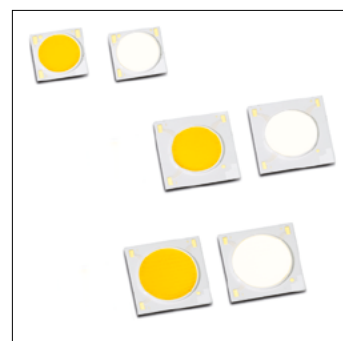

Two-piece PCB holder

For LUGA PCBs with dimensions: 19x19 mm
U_{max.}: 250 V DC for basic insulation
I_{max.}: 3 A
Type: 89731, packaging unit: 210 pcs.
Ref. No.: 564174 base holder
Ref. No.: 564170 cover

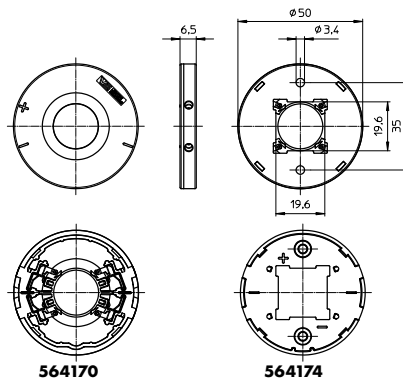

Two-piece PCB holder

For LUGA PCBs with dimensions: 28x28 mm
U_{max.}: 330 V DC for basic insulation
I_{max.}: 3 A
Type: 89730, packaging unit: 210 pcs.
Ref. No.: 564173 base holder
Ref. No.: 564169 cover

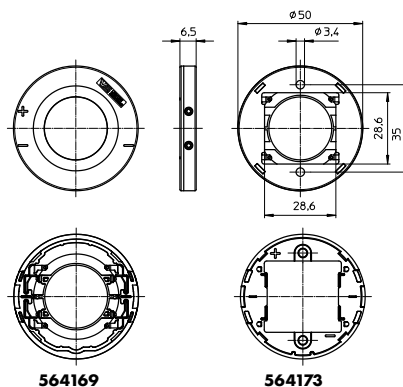

Diffuse cap

Diffuse LES protection cover for mixing different colour temperatures for use with Tuneable White modules
Optical efficiency: 95 %
Material: silicone, translucent
Temperature resistance: up to 150 °C
Fixation: base insertion and clamp in covers types 89730/89731
Weight: 1.2/1.9 g
Packaging unit: 210 pcs.
Ref. No.: 566485 for LUGA PCBs 19x19 mm
Ref. No.: 566484 for LUGA PCBs 28x28 mm

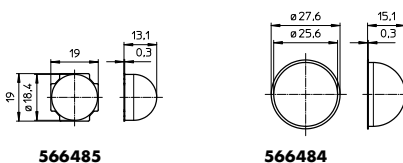

The values contained in this data sheet can change due to technical innovations. Any such changes will be made without separate notification.

Installation Instructions for PCB Holder Type 89730/31

Step 1

Position fixing plate in the luminaire

Step 2

The base holder has to be attached to the luminaire or heat sink using two screws (M3).

Min. torque: 0.3 Nm

Max. torque: 0.5 Nm



Step 3

Position LUGA PCB in the fixing plate.

If required, a self-adhesive thermal foil can be used.

CAUTION: When inserting the PCB, it is critical to ensure correct positioning of the plus and minus poles!

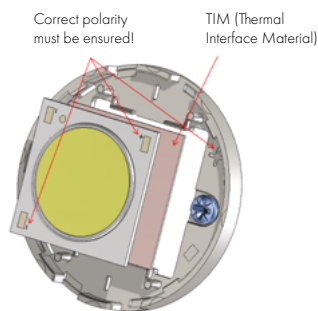

Step 4

Clip the cover with the preassembled contacts onto the fixing plate.

Correct mounting (polarity) is ensured by an anti-rotation element on the inside of the holder.

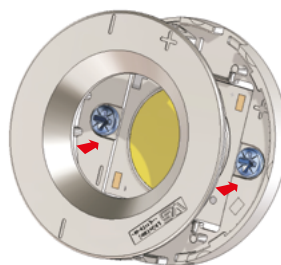

Step 5

The electrical connection is made by pushing the stripped leads into the lateral openings.

The holder has 4 permanent push-in connectors, for solid or stranded wires with tinned wire ends.

Conductor cross-section: 0.5–0.75 mm²

Stripped length: 7^{+0.5} mm

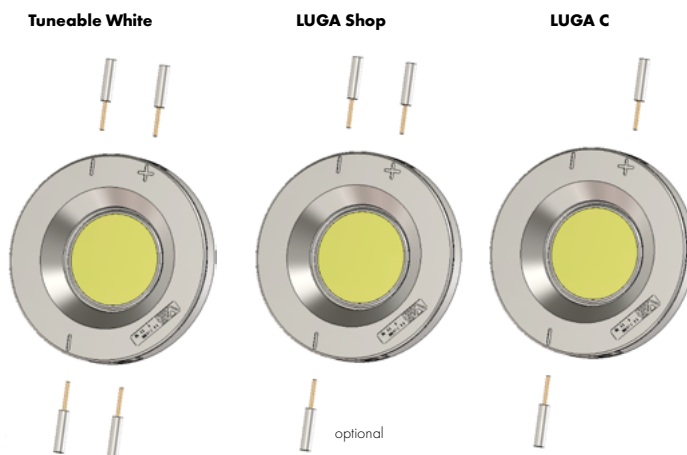

The values contained in this data sheet can change due to technical innovations. Any such changes will be made without separate notification.

Thermal Pads

Phase-change thermal pads (PC TIM)

Material: phase change material, wax-based

Softening temperature: 45 to 55 °C

Solid material at room temperature for easy assembly

The liquid phase of the material can fill interface irregularities with much higher efficiency than traditional gap fillers.

For optimum heat dissipation

Unit: 1 pcs.

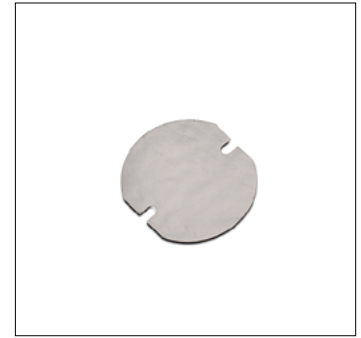
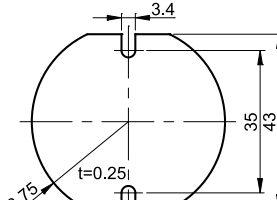

Type	Ref. No.	Size mm	Thickness mm	Material	Softening temperature °C	Thermal conductivity R _{th} W/mK
PC pad Ø 50	561003	Ø 47.5	0.25	Phase Change TIM	45 to 55	3

As a result of the growing efficiency of LED modules and ever decreasing heat generation in LED modules, in rare circumstances the design of the cooling systems/heat sinks can lead to the recommended "softening temperature" of 55 °C not being attained.

In such a system the mentioned phase change material is not suitable for the application since the temperature needed for phase reversal is not reached.

Installation Instructions for PCB Holder LUGA Shop

Thermal Interface

The temperature of the LUGA module depends on the luminaire design (size of heat sink), and the thermal resistance between LED ceramic board and heat sink. Temperature on t_p/t_c point has to be measured in complete luminaire setup acc. to EN 60598. Exceeding the maximum rated t_c -point temperature (see datasheet) of the LED module can lead to the destruction of the LED module. The expected lifetime of LED modules depends on the driving current and t_p -temperature during operation (see corresponding data table in datasheet).

It is recommended to use only thermal interface materials (TIM) soft enough to contact the whole surface with a pressure $< 1 \text{ N/cm}^2$ (phase changing materials or thermal grease). Avoid graphite tape and other rigid materials. Allowed thickness of TIM: 0–0.2 mm (if TIM size = PCB size).

Suitable/tested* interface materials:

- Thermal phase change material:
561003 PC-Pad for LUGA, $\varnothing 47.5 \text{ mm}$ designed to be used with $\varnothing 50 \text{ mm}$ holder
- Thermal paste: e.g. KERAFLON "Keratherm KP12" (thermal paste needs to be applied flat and homogenous between LED module and heat sink)

*Thermal management of luminaire depends on the luminaire design, the luminaire production process and the thermal interface material used. VS does not assume any liability for luminaire thermal management and for the long-term behaviour of used thermal interface materials. Please consider the data sheets or installation manuals of the used interface materials.

General safety and installation guidelines

Installation must be carried out under observation of the relevant regulations and standards. The LED modules are designed for operation within a casing or luminaire. Installation must be carried out in a voltage-free state (i.e. disconnection from the mains). The following advice must be observed; non-observance can result in the destruction of the LED assembly modules, fire and/or other hazards.

- ESD (electrostatic discharge) protection measures must be observed when handling and installing the LED modules. See VS's application notes on ESD protection.
- LED assembly modules must not be subjected to any undue mechanical stress, e. g.:
 - do not treat as bulk cargo
 - avoid shear and compressive forces during handling and installation
 - do not damage circuit paths
 - do not touch the yellow phosphorus layer
- The module must be fixed onto a thermally conductive surface.

- Safe operation only possible by the use of external constant current sources (I_{max} , see table "Electrical Characteristics").
- Operation only with power supply units that feature the following protection:
 - Short-circuit protection
 - Overload protection
 - Overheating protection
 - SELV (Safety Extra Low Voltage); $U_{\text{max}} \leq 60 \text{ V}$
 - I_{max} (see table "Maximum Ratings") must not be exceeded.
- When operating devices will be selected care has been taken to ensure that the maximum values (see table "Maximum Ratings") will not be exceeded.
- Please ensure the correct polarity of the leads prior to commissioning. Reversed polarity can destroy the modules.
- Safety regulations acc. to EN 60598 (or further standards) has to be observed if the maximum output voltage exceed the permitted touchable value.
- A parallel connection of the modules is not allowed.
- To ensure problem-free operation, the specified maximum temperature at the t_c point (see "Operating Life") must be observed (and measured in accordance with EN 60598-1). To satisfy this point, it may be necessary to put measures in place to ensure any heat is dissipated from the PCB to the environment.
- In the event of outdoor applications or applications in damp locations, care must be taken to protect LED assembly modules against humidity, splashes and jets of water. Any corrosion damage resulting from humidity or contact with condensation will not be recognised as a defect or manufacturing fault. LED assembly modules are not specially protected against foreign bodies or dust. Depending on the type of application, further protection must be ensured to prevent dust and foreign bodies from entering.
- Operating LED modules in the presence of certain chemical substances or in chemically enriched (aggressive) environments can impair module functionality or even cause total module failure. Detailed information can be found in our "Chemical Incompatibility" PDF on our website www.vossloh-schwabe.com/en/home/products/led-lighting-technology/notes-on-led-technology.html

The values contained in this data sheet can change due to technical innovations. Any such changes will be made without separate notification.